



# DEXON CANADA AIR SYSTEMS INC.

## TROUBLE SHOOTING GUIDE for RVDH SERIES

There is no lit LED on the status board	<ol style="list-style-type: none"> <li>1. Check control power to TB7 in blower heater.</li> <li>2. Check control power fuse and for short circuits.</li> <li>3. Check fuse on RVDH Main Controller.</li> <li>4. Check RVDH Main Control Board for damage or for short circuit.</li> <li>5. Check that the transformer on main controller hasn't come loose or is damaged.</li> <li>6. Check for 12VDC between brown and grey wires to the status board at TB3 on RVDH Main Controller and the same wires on the status board.</li> </ol>	<ol style="list-style-type: none"> <li>1. Restore power.</li> <li>2. Replace fuse if required.</li> <li>3. Replace fuse if required.</li> <li>4. Replace or have RVDH Main Controller repaired.</li> <li>5. Send RVDH Main Controller in for repairs if required.</li> <li>6. If 12VDC is not present check connections, for short circuit or controller damage and send in for repair if required.</li> </ol>
"No Air" LED is on	<ol style="list-style-type: none"> <li>1. Check the "Low Temp." LED for indication of a "Low Temp." shut down condition.</li> <li>2. Check fan; if it's not running check fan terminals for corrosion, frost build up or impeller restrictions.</li> <li>3. Check for fan power at TB5 on RVDH Main Controller. If no power; check connections, check for short circuit or controller damage.</li> </ol>	<ol style="list-style-type: none"> <li>1. If shut down press the "Reset" switch.</li> <li>2. Remove restrictions and replace fan if required.</li> <li>3. If damaged replace or send RVDH Main Controller in for repairs.</li> </ol>
"Low Temp." LED is on	<ol style="list-style-type: none"> <li>1. Check for element power at TB8 in blower heater.</li> <li>2. Visually inspect all Klaxon thermostat(s) on the elements and on the Heat Sink above the elements for damage or corrosion.</li> <li>3. Ensure the unit is not in "Manual" mode.</li> <li>4. Check that the fan voltage is set as per specifications (see quality control test report).</li> <li>5. Check if the "Overheat" LED is on.</li> </ol>	<ol style="list-style-type: none"> <li>1. Restore power.</li> <li>2. Replace damaged Klaxon thermostat(s) if required.</li> <li>3. Set to "Auto" and press "Reset" switch.</li> <li>4. Adjust as required.</li> <li>5. If on see "Overheat" LED below.</li> </ol>
"Overheat" LED is on	<ol style="list-style-type: none"> <li>1. Check overheat thermostat for continuity between the leads at TB4 on main board. It should be in a closed circuit condition.</li> <li>2. Check element relay(s) for current leakage by disconnecting control power to eliminate any demand and check for a current draw on the element power supply leads.</li> </ol>	<ol style="list-style-type: none"> <li>1. If in open circuit condition check the thermostat for damaged leads and replace as required.</li> <li>2. If there is current draw and there is no demand replace the relay(s).</li> </ol>
"Element" LED is off or inactive	<ol style="list-style-type: none"> <li>1. Check that the ambient outdoor temperature is not above the discharge set point as indicated on the quality control test report in appendices.</li> <li>2. If the ambient temp. is below the set point check if unit is in "Low Temp." shut down condition or in "Overheat" due to corroded overheat thermostat.</li> <li>3. Check that there is power to the status board and TB7 on the main controller.</li> </ol>	<ol style="list-style-type: none"> <li>1. If the ambient temperature is above the set point then there is no demand; unit is working as intended.</li> <li>2. Refer to "Low Temp." shut down and "Overheat" conditions above.</li> <li>3. Refer to status board "Power On" condition above.</li> </ol>

If the above recommendations do not solve the problem please contact Dexon Canada Air Systems at 403-930-1284 or email [techsupport@dexoncanada.com](mailto:techsupport@dexoncanada.com).

# RVDH MAIN CONTROL BOARD

“Low Temp.” shut down bypass timer LED: The LED will blink until the timed delay has ended. Note: In order to allow time for the heat sensor to reach its set point temperature a 7-8 minute bypass is built into the controller for cold starts. If the discharge temperature is below 0°C and the set point is not reached in the allotted time the blower heater will go into a “Low Temp.” shut down condition.

To normally closed  
overheat thermostat  
in heat exchanger

12VDC output to  
Crydom SS Heating  
Relays. May be  
Pulsing or Steady  
stg3 stg2 stg1 12VDC

Heat 3  
Heat 2  
Heat 1  
Overheat  
Common  
Low Temp.  
No Air  
Fan Manual Mode  
Manual Reset  
Fan SC Display  
+5Volt Power  
+12V Power  
TO STATUS BOARD

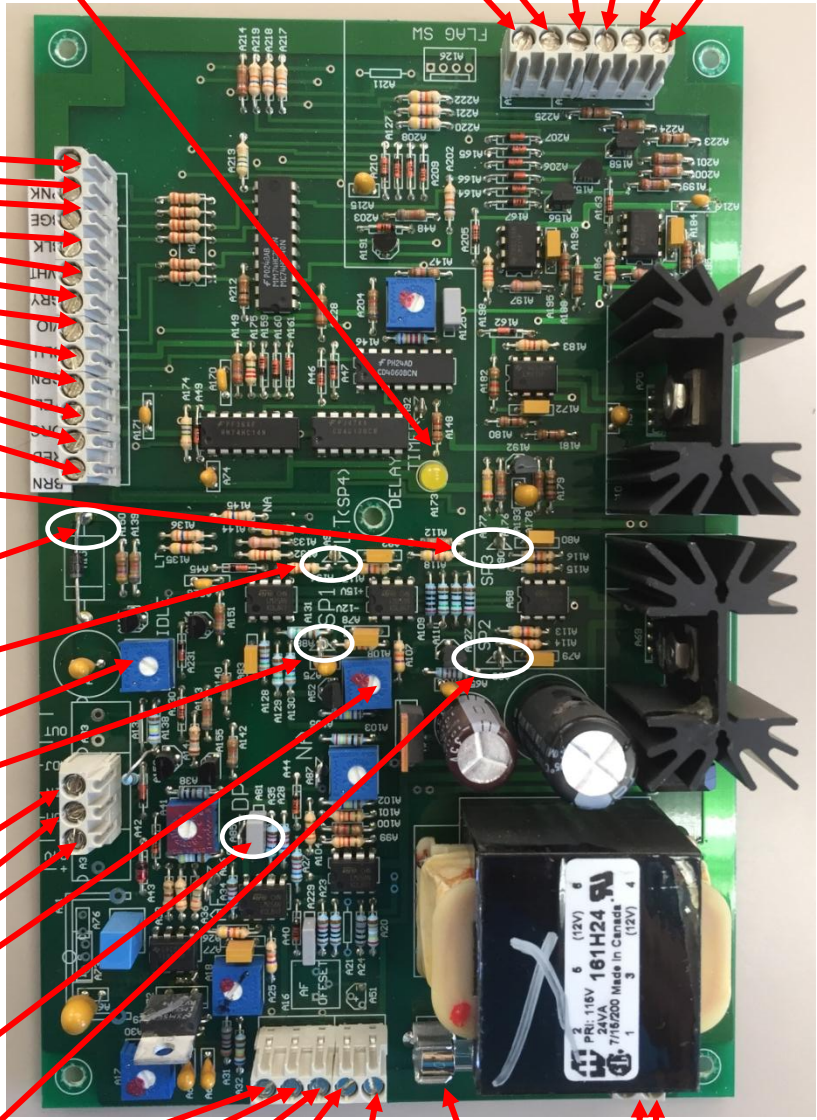

“SP3” – Stage 3 Temp. Set Point Test Pin.  
Positive Lead on DC Volt Meter 0-20V Range

“COM” Common Test point. Negative Lead on  
DC Volt Meter 0-20V Range

“SP4” – Low Temp Restart Test Pin. Positive  
Lead on DC Volt Meter 0-20V Range

Fan Idle Adjustment Potentiometer

“SP1” – Stage 1 Temp. Set Point Test Pin.  
Positive Lead on DC Volt Meter 0-20V Range

0 to 10VDC should be present here. Fan volts are variable with Fan Adjustment Pot	0-10VDC 24/48VDC Com
---	----------------------------

“SP” – Set Point Potentiometer for Discharge  
Temperature Adjustments

“DP” – Discharge Temperature Test Pin.  
Positive Lead on DC Volt Meter 0-20V Range

“SP2” – Stage 2 Temp. Set Point Test Pin.  
Positive Lead on DC Volt Meter 0-20V Range

+5V AT +12V AV Com  
Interfacing with Airflow  
Sensor Board RVDHAFS

120Volt Power  
120VAC should be  
present here

Controller Fuse Brackets – 750MA -  
Type AGC Fuse

**IMPORTANT: Please contact Dexon Canada Air Systems Inc. before adjusting any potentiometers (pots). There are only 2 pots that can be adjusted onsite and this should only be done when absolutely necessary and by qualified personnel only.**

## RVDH MAIN CONTROLLER TEST PINS DESCRIPTION

NOTE: We recommend using “Minigrabber” type test leads that clip/hook on to the test pin holes for measurements on the main controller to prevent accidentally shorting out test pins to components in close proximity. IMPORTANT: When taking measurements the voltage does not equate exactly to temperature, there is a 0.1VDC offset; for example (0.7VDC = 6°C), (1.1VDC = 10°C), (0.9VDC = 8°C).

TEST PIN	DESCRIPTION
COM	- Is the common point for all RVDH Main Controller and Airflow Circuit Board voltage tests (0-24VDC Range). The negative from a DC Volt Meter goes here for each sampling.
DP	- Is the Discharge actual temperature as per the temperature sensor located near the bottom of the blower heater in a small aluminum tube (See Dexon RVDH Main Controller for Temperature Sensor Jack).
SP1	- Is the set point temperature that will be maintained at the blower heater discharge at the bottom of the blower heater. The desired temperature may be adjusted by turning “SP” (Set Point discharge temperature adjustment potentiometer) clockwise to increase or counter clockwise to decrease. Typical range is +5°C to +10°C (0.6VDC to 1.1VDC). IMPORTANT: Please contact Dexon Canada Air Systems Inc. (403-272-0562) before making any adjustments to any potentiometers. Note: the airflow in “Auto” mode is preset by Dexon based on airflow requirements and heating capacity. Increasing the airflow should only be done if airflow is inadequate due to unforeseen on-site piping/ducting friction. Adjustments should only be made when absolutely necessary and by qualified personnel.
SP2	- Is the set point at which the stage 2 element will engage in order to maintain SP1 set point. As the outdoor temperature drops the stage 2 elements are called upon to provide heat when the DP (down pipe) temperature sensor drops to where the SP2 set point is set. Typically 0.5VDC = +4°C.
SP3	- Is the set point at which the stage 3 element will engage in order to maintain SP1 set point. As the outdoor temperature drops the stage 3 elements are called upon to provide heat, when the DP (down pipe) temperature sensor drops to where the SP3 set point is set. Typically 0.35VDC = +4.5°C.
SP4	- Is the low temperature automatic restart set point. This is the temperature at which the blower heater will automatically restart after a “Low Temp.” shut down has occurred. A “Low Temp.” shut down occurs when the discharge temperature drops below 0°C (typically) and the fan shuts down to prevent freezing of the ventilated space. As the outdoor temperature warms up the fan will automatically reset and start up based on the SP4 temperature set point. Typically 0.2VDC = +1°C.

CONTACT INFORMATION:  
 Email: [techsupport@dexoncanada.com](mailto:techsupport@dexoncanada.com), Website: [www.dexoncanada.com](http://www.dexoncanada.com)  
 Tech Support Phone: 403-930-1284, Admin Phone: 403-272-0562

## AIRFLOW SENSOR BOARD – RVDHAFS

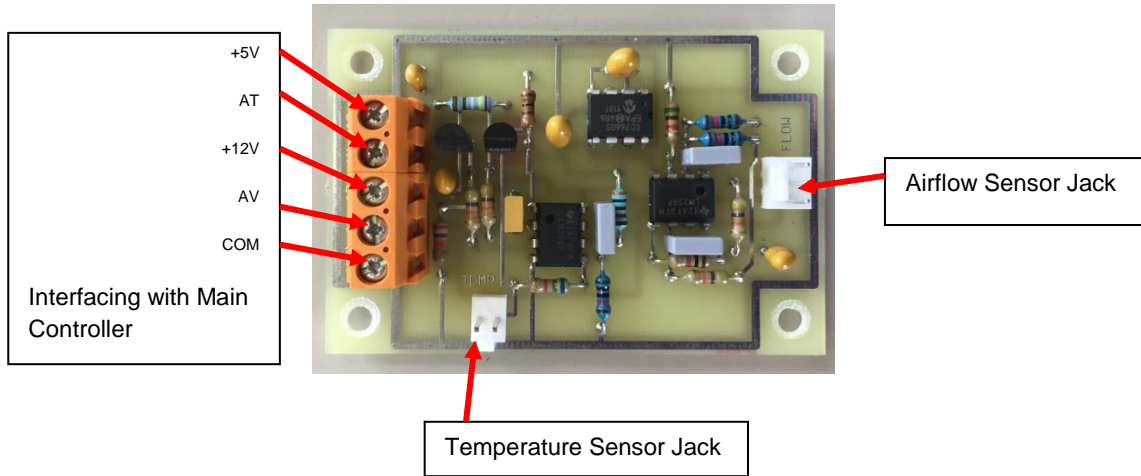

## STATUS BOARD – RVDHSTS

The information provided on these pages assumes there IS a problem and there are no issues with the RVDH Main Controller, the RVDHSTS Status Board or wiring problems.

“Power On” Indication via “Running Level” bar graphs: When the “Set Level” and “Running Level” are lit the status board is receiving power from the main controller located inside the blower heater. If it is not lit - check to ensure the control power circuit is energized inside the blower heater. If the circuit is energized; check the fuses leading up to and on the main controller then check the wiring between the blower heater and the status board.

“Element 1” LED: When this LED is blinking/pulsing it’s an indication that the outdoor temperature is such that the main controller is calling for heat. The continuous blinking/pulsing indicates that the blower heater is easily maintaining the pre-set discharge temperature. Note: “Element 2” and “Element 3” LEDs will only be active when stage 1 cannot maintain the preset discharge temperature on its own and stage 2 and/or stage 3 elements are required. These LEDs will not blink/pulse; stage 2 and 3 elements are only called upon when stage 1 cannot maintain the preset discharge temperature on its own.

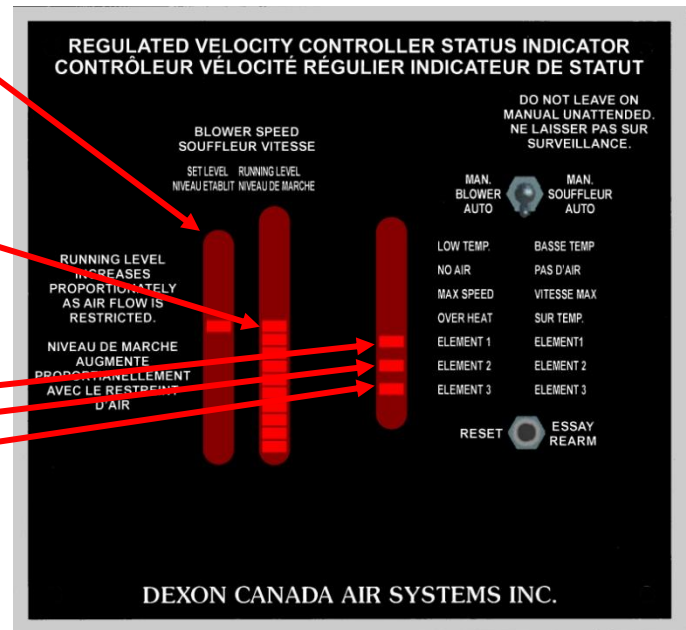

Figure 1: Normal Operation

“Overheat” LED: When lit indicates that an “Overheat” condition has occurred. This condition may be the result of either the Crydom Solid State Relay failing, the overheat thermostat at the top of the heat exchanger has had its wiring corrode off or has opened its internal contact (normally closed contact becomes open).

Relay Fail test: Turn off the control power and check for current in the heating circuit. If a current is measured the relays could be leaking across their voltage barrier, have found a current path to ground or have completely shorted out.

Overheat Sensor test: If the relays are fine check the continuity of the overheat thermostat, it should be in a normally closed state to allow heating. See Dexon RVDH Main Controller page for location of the overheat thermostat wires.

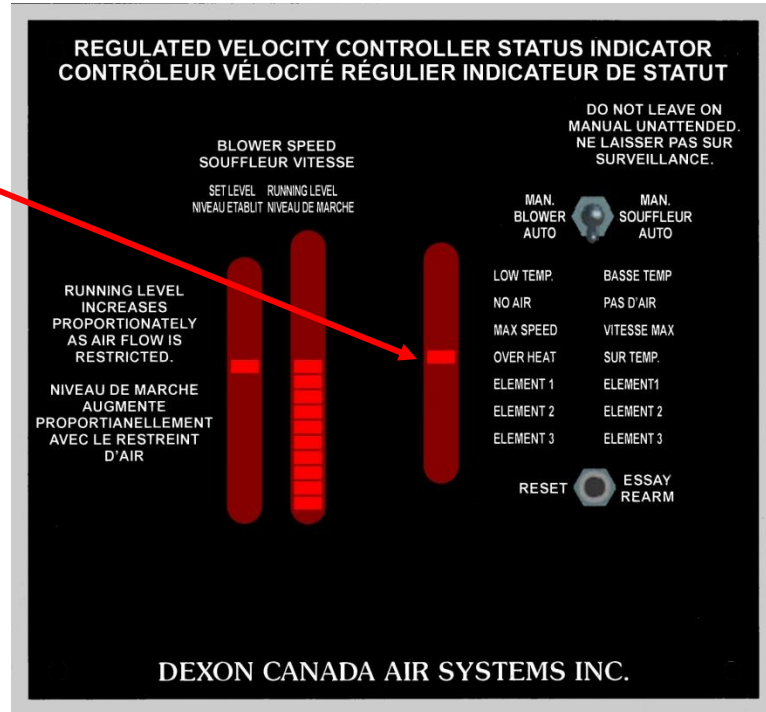

Figure 2: “Overheat” Indication

“Blower Speed” bar graphs, “No Air” & “Max Speed” LEDs: If the “Max Speed” and “No Air” LEDs are both lit and the “Running Level” has reached the top of the bar graph, this could be an indication that either the fan or airflow sensor has failed, the filters are completely saturated or there is an obstruction to the airflow and the safety ventilation is being compromised. If there is confirmation of the fan running there may be issues with the RVDH Main Controller or status board. If fan is not running; confirm that there is power output from the RVDH Main Controller to the fan. If you confirmed the fan is running and there is still a “No Air” indication then there is an issue with one or more of the control boards.

IMPORTANT: When the “No Air” LED is lit the heating elements are disabled for safety. If the outdoor temperature is below 0°C this will lead to a “Low Temp.” shut down condition; if this does occur then the “Low Temp.” LED will also light up.

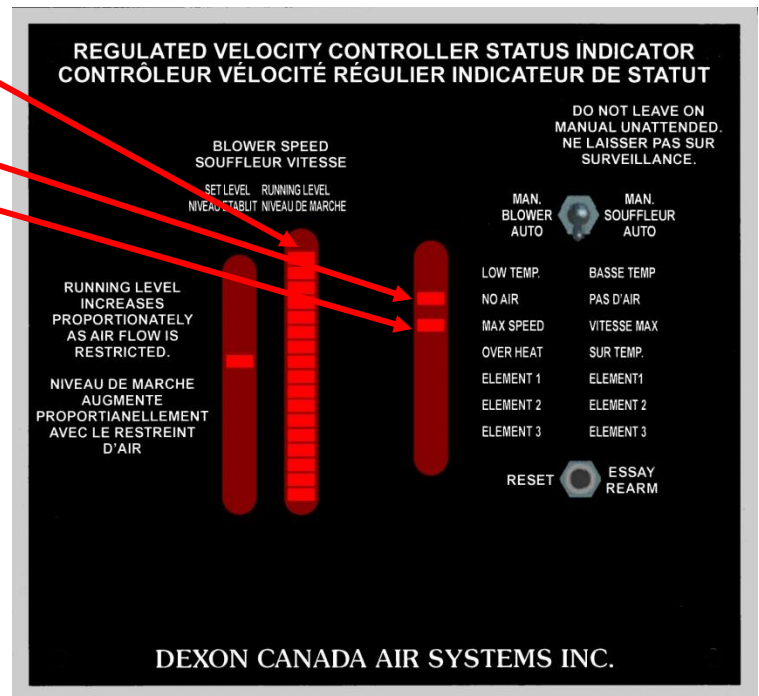

Figure 3: “No Air” Indication

“Blower Speed” bar graphs, “No Air” & “Low Temp.” LEDs: This condition is most common in cold temperatures. This can be due to a “Low Temp.” shut down condition which causes the “No Air” indication or a “No Air” indication which activates the “Low Temp.” shut down feature since the “No Air” condition will disable the heating elements. This occurs at temperatures below 0°C (typically).

The “Low Temp.” LED: Will light up due to a lack of heating; the heating circuit is off or one or more heat sensors are open. If the main overhear sensor is open an “Overheat” LED will also be lit (Fig. 2). This is most commonly due to corroded wire leads in the heat exchanger. It could also be caused by a temperature sensor failure, a sensor out of calibration or the RVDH Main Controller has failed.

Note: A “Low Temp.” condition can also occur in Class 1, Div. 2 blower heaters as they have overhear thermostats mounted directly on each of the heating elements. These normally closed thermostats shut down the heating if the heating element skin temperature reaches close to ignition temperature of the gases in the Gas Groups C & D. There is no status indication for this condition; check for open contact, corroded wires etc.



Figure 4: “No Air” Indication with “Low Temp.” Indication

The “No Air” LED: Will light up in the event of a fan failure or if a “Low Temp.” condition occurred as described above. Check the fan for operation and check to ensure the heating circuit is energized (breaker is on).

**“Manual/Auto” Toggle Switch:  
DO NOT LEAVE UNIT IN MANUAL MODE  
UNATTENDED**

This switch is primarily used to purge, flush or ventilate a confined space prior to entry.

In “Auto” mode the blower heater runs at a preset level based on the required airflow rate; generally based on the area of the space and the safety ventilation requirements of the location. For continuous airflow in “Auto” mode all safety features of the unit are active.

In “Manual” mode the fan is put into full speed causing the “Running Level” bar graph to reach the top and the “Max Speed” LED to light up; this is to purge/flush/ventilate the space only. This is not meant for continuous operation since the heating capacity of the unit is sized for only the continuous airflow rate.

It is important to note that in “Manual” mode the “Low Temp. shut down feature is bypassed/disabled to ensure the unit does not shut down while the confined space is occupied. This bypass can be used to allow heating even in a “Low Temp.” shut down in order to defrost the fan if frosted up. The fan will often restart once thawed.

**“Reset” Switch:**

This switch is used in order to start a bypass timer built into the main controller that will allow heating for roughly 7-8 minutes regardless of the “Low Temp.” shut down condition. This is done in an attempt to warm the temperature sensor above freezing and remove the “Low Temp.” shut down condition. This is provided the heating elements have power and the “No Air” LED is not lit.

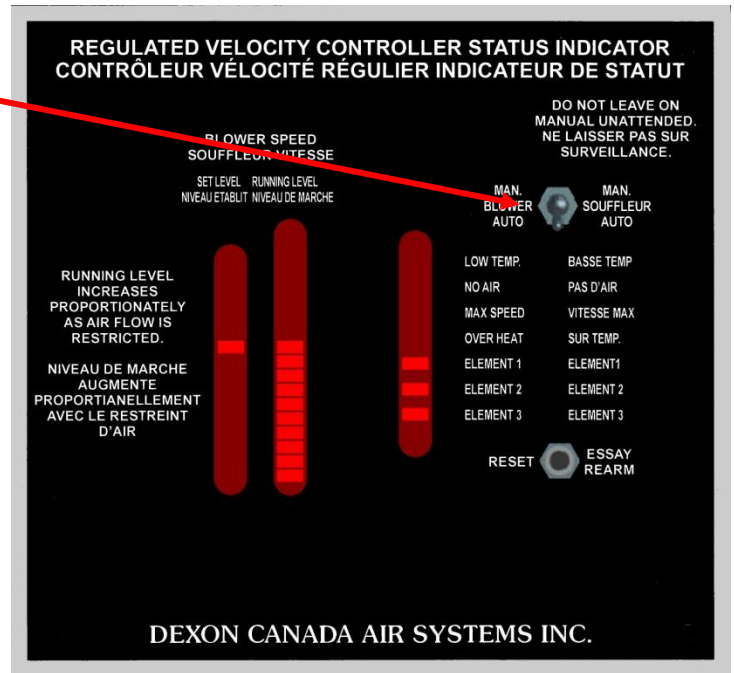

Figure 5: “Manual/Auto” Toggle Switch

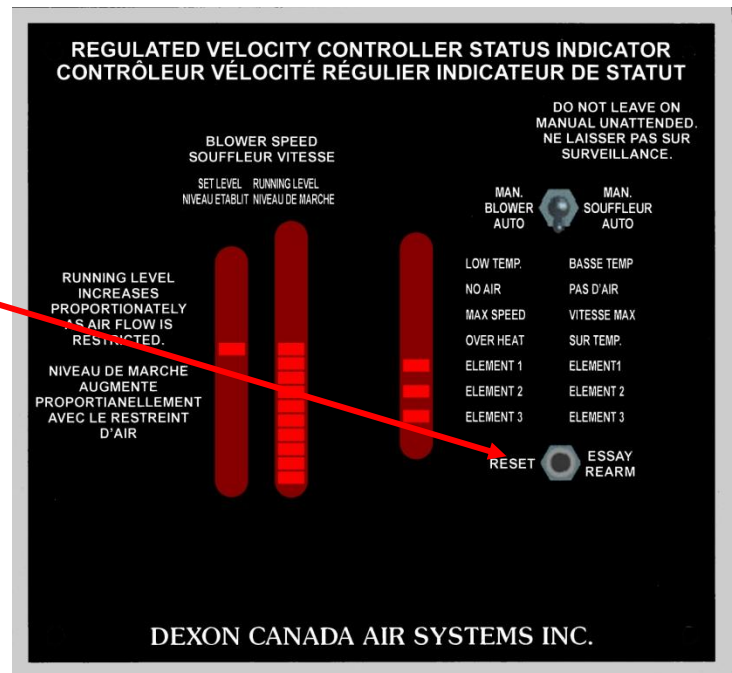

Figure 6: “Reset” Switch

**CONTACT INFORMATION:**

Email: [techsupport@dexoncanada.com](mailto:techsupport@dexoncanada.com), Website: [www.dexoncanada.com](http://www.dexoncanada.com)  
Tech Support Phone: 403-930-1284, Admin Phone: 403-272-0562